

OVERVIEW

The Pathport® DIN-mount 4-Port Gateway (PWPP DIN P4) provides the full functionality of other Pathport gateways in a compact, DIN-rail mountable form factor.

System integrators can now easily put fully customized universes of DMX where they are needed. Ideal for use in NEMA enclosures. Fully compatible with DIN interfaces (PWINF).

CONNECTIONS

The Pathport PWPP DIN P4 features terminal strips that can be removed from the card to facilitate easy wiring installation or replacement. Make the following connections, **WITH THE POWER TURNED OFF**.

POWER

The PWPP DIN P4 is designed to run on either Power-over-Ethernet (PoE), or on an auxiliary power supply providing between 24 and 48 volts DC. The gateway is Class 2 PoE and will draw up to 8 Watts.

If an auxiliary supply is used, observe the correct polarity when wiring the power IN terminal plug. The earth ground terminal must be connected to the enclosure's chassis or electrical ground terminal to ensure EMC compliance.

DMX512

DMX connections consist of a shield and data pair. Connect DATA+ and DATA- to D1+ and D1-. Observe the same polarity convention throughout the system. Connect the cable shield or common to the SHLD COM terminal.

NETWORK

All network wiring should follow standard Ethernet rules and be installed by a qualified person. As part of the installation, all wiring should be certified under the TIA/EIA-568 standard.

CONTACT CLOSURE INTERFACE (CCI)

There is a 3-pole terminal connector included for dry contact closure input. The CCI supports two functions: **DMX Hold** and **RDM Pause**. See the Pathscape Manual for details on how to enable these functions



STATUS INDICATORS

- PROCESSOR** *Green.* Steady heartbeat indicates processor is running; off indicates no power.
- RJ45 LEDs** The RJ45 Ethernet jack has two green LEDs. One will glow steady when the link is up and the other will flash with activity.
- DMX INPUT** *Amber.* Steady glow indicates port is receiving active DMX. Blinking indicates no incoming DMX signal. Off indicates Port is Disabled.
- DMX OUTPUT** *Green.* Steady glow indicates port is transmitting DMX. Blinking indicates no DMX output. Off indicates Port is Disabled.
- IDENTIFY** *Blue.* Blinks when identify is active.
- SD CARD OK** *Green.* Steady glow indicates microSD card is present. Off indicates no SD card present or SD card error/cannot be read.

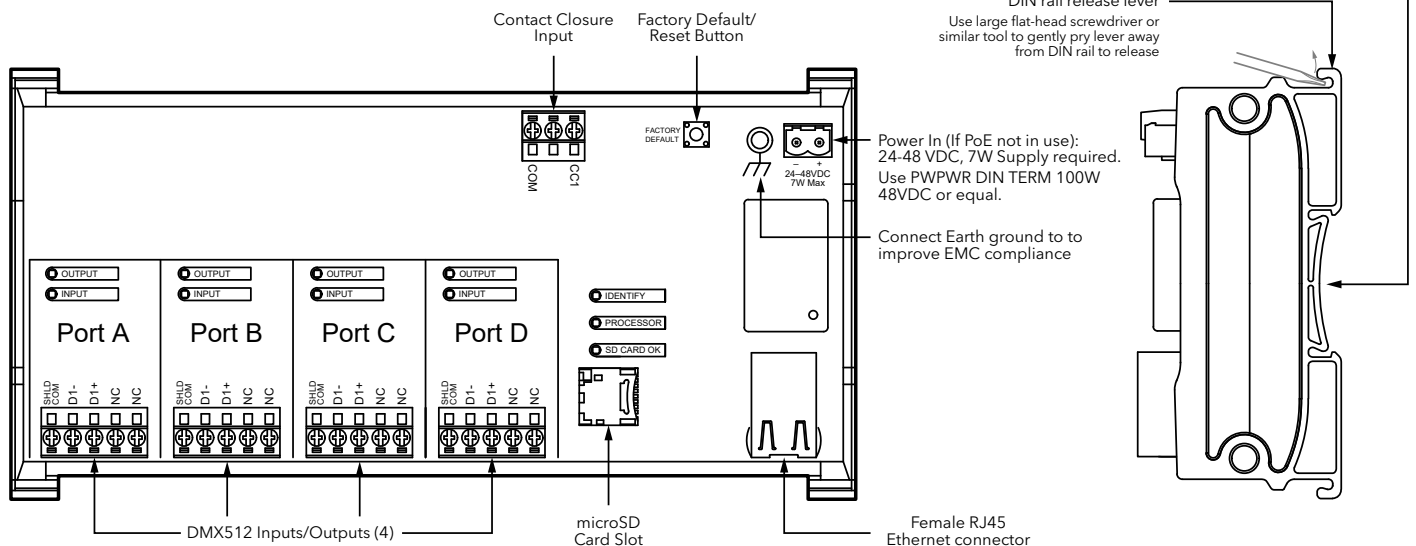

INSTALLATION

- Disconnect all power before proceeding with installation.
- Securely mount DIN rail (if not already installed in an enclosure). To mount the PWPP DIN P4, hook the upper slots on the back of the plastic extrusion to the DIN rail and then gently but firmly press on the bottom front corners of the extrusion to snap the module onto the rail. **DO NOT press directly** on the PCB card itself.
- If the PWPP DIN P4 is using an auxiliary power supply, connect the power IN terminal plug, after checking that polarity is being observed. The earth ground terminal must be connected to the enclosure's chassis or electrical ground terminal to ensure EMC compliance. Restore power and the card will boot up.
- Attach the network cable to the RJ45 connector. Because good wiring practice requires building wire to terminate with a female connector, typically a short (12"/30cm) male-to-male jumper is used. If PoE is being used, the card will boot up. Both auxiliary power and PoE may be connected simultaneously without damaging the PWPP DIN P4.
- The system is now ready for testing.
- To remove the PWPP DIN P4 from the DIN rail, use a flathead screwdriver to gently pry the hooked foot on the end caps of the device away from the DIN rail. The corner of the device should lift free; repeat at the other side and unhook the device from the rail.

DEFAULT SETTINGS

The PWPP DIN P4 ships as a DMX output gateway with **Pathway ssACN** enabled.

The following Ethernet receive protocols are unsecured and are **NOT ENABLED** by default: **Pathport, Strand Shownet, ETC Net2, E1.31 streaming ACN** and **Art-Net**.

Before configuring and using the PWPP DIN P4, you must add it to a **Security Domain** using Pathscape.

To use the other listed unsecured protocols, you must use Pathscape and enable the device property ALLOW UNSECURED RX (see below).

PATHSCAPE CONFIGURATION

A large number of parameters may be customized for the PWPP DIN P4, including: port direction, output channel patch, input universe number, transmit and receive protocols and DMX speed. Network properties such as IP address and subnet mask are also customizable by the user.

Detailed gateway configuration and overall network system management are done using Pathscape software, which is available for download from www.PathwayConnect.com

Please refer to the **Pathscape manual** for information on configuring these additional properties.

IMPORTANT - UNSECURED NETWORK PROTOCOLS

Due to new cybersecurity laws, all Pathport devices shipped after January 1, 2020 have security properties enabled. This means that by default, the device is not set up to receive unsecured network protocols such as Art-Net, E1.31 sACN, ShowNet, NET2 or Pathport Protocol.

You must add the Pathport to a Security Domain using Pathscape before configuration and use.

Pathway ssACN (Secure sACN) is enabled by default.

To use the above unsecured protocols, open Pathscape. In the Pathport base device properties, under the **Network DMX Receive Protocols** section, click the **Allow Unsecured RX** checkbox.

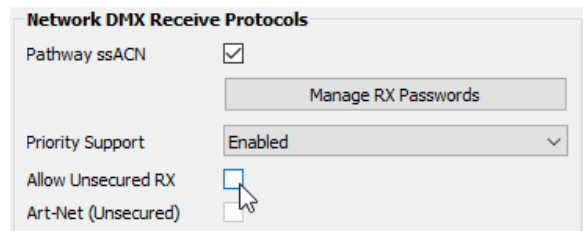

Once checked, you may select the network protocol(s) to receive.

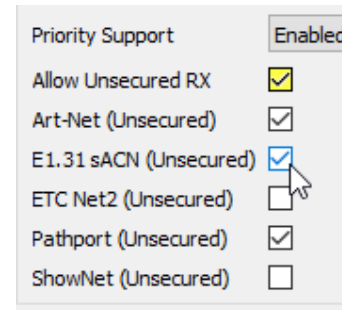

For further information, please see the following sections in the **Pathscape manual: Security, Pathport Properties > Network DMX Receive Protocols**.

SD CARD BACKUP

When a new, unused (formatted) microSD card is inserted into the PWPP DIN P4 card slot, the gateway's current configuration will be automatically copied to the SD card.

When a microSD card containing a saved configuration for a PWPP DIN P4 is inserted into another PWPP DIN P4, the configuration will automatically be copied from the SD card into the gateway.



ELECTRICAL INFORMATION

- PoE-powered Class 2 device, 7W max power consumption
- Auxiliary input voltage, 24-48V
- 3000V isolation between DMX ports
- 60V protection on each port
- 10Mb TCP/IP connection

COMPLIANCE

- ANSI E1.11 DMX512-A R2013
- ANSI E1.20 RDM(2010) - Remote Device Management
- ANSI E1.31 sACN - Streaming ACN, Art-Net, Strand ShowNet, Pathway ssACN
- ANSI E1.33 RDMnet - RDM over IP
- IEEE 802.3af Power-over-Ethernet
- Class 2 Low Voltage
- California Title 1.81.26, Security of Connected Devices
- CE
- RoHS 2011/65/EU + A1 2015/863

PHYSICAL

- 8"W x 4"H x 1.9"D (203mm x 103mm x 48mm)
- 0.4 lbs (0.18 kg)
- Operating Conditions: 14°F-113°F (-10°C to 45°C); 5-95% relative humidity, non-condensing