

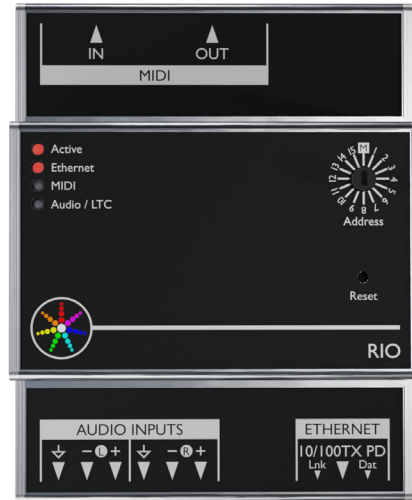

## Remote Input Output Audio

The Pharos RIO A (Remote Input Output Audio) device provides a convenient and scalable way to add audio integration to your Pharos Designer system. The RIO A has an audio input, supporting linear timecode or up to 30 band spectrum analysis, as well as a MIDI input and output. Each device can be placed where it is needed and connected to the Controllers over an Ethernet network.



## RIO A Features



### Designer Trigger

Timing is everything. Whatever the stimulus, Designer Trigger can handle it. You can control your lighting with responsive, reactive programming. Designer Trigger is a rules engine that uses conditional logic and a broad range of interfaces and protocols. Send and receive any command, to and from any system. Conditional logic is supported, along with a powerful built-in scripting language for unlimited flexibility.



### Audio Response

The stereo balanced line level audio input supports auto or manual gain (adjustable in software). The spectrum analysis is configurable from 3 to 30 bands on each channel, and triggers can be set on the instantaneous or peak level of any band or the overall volume. Up to 4 simultaneous audio inputs are supported with multiple RIO A units.

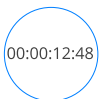

### Timecode

The audio input can also be configured to receive linear timecode on either channel. The format is auto-detected and supported formats are 24fps (film), 25fps (EBU), 29.97fps (NTSC) & 30fps (SMPTE). MIDI Time Code (MTC) can also be received via the MIDI input. A software flywheel with error correction and jump support ensures smooth but responsive timecode playback. Up to 12 simultaneous Timecode inputs are supported with multiple RIO A units.



### Scalable

Up to 200 Remote Devices can be combined with one or more Pharos Designer Controllers on the same network to build the ideal system for your installation. Each Remote Device is easily addressed using a convenient thumb wheel. Whether one Controller or many, it's all easily programmed using our Designer software.



### MIDI

Musical Instrument Digital Interface (MIDI) is a standard serial protocol commonly used to link musical instruments and synthesizers – but it is also used for show control and timecode. The RIO A provides both an input and output on standard 5-pin DIN connectors.



### Power-over-Ethernet

As a Power-over-Ethernet (PoE) device, the RIO can be placed at any remote location and only needs a single Cat5 cable that provides both power and data.



### Pharos Designer

Programmed and configured using the free Pharos Designer software – available for Windows or Mac OS X – with upload over Ethernet.



### Installer Friendly

Made for permanent installation, with installer-friendly 0.200" (5.08mm) plug-in rising clamp terminals, a rugged, compact enclosure, and easy DIN rail mounting.

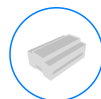

### Network

Works with any Pharos Designer Controller and links to it using standard protocols over an Ethernet network.



## Capabilities

<b>Audio In</b>	Volume level and up to 30 band spectrum analysis per channel, including peak decay rate control and manual or automatic gain Maximum 4 audio inputs per system
<b>Timecode</b>	Timecode support via MIDI (MTC) or either audio channel (LTC) User configurable fly-wheel, error correction routines and jump support Maximum 12 Timecode inputs per system LTC format auto-detection with support for 24fps (film), 25fps (EBU), 29.97fps (NTSC) & 30fps (SMPTE)
<b>MIDI</b>	Input and Output of freely configurable Short messages (Notes), MIDI Show Control or Extended Messages using convenient message composer or MIDI Time Code (MTC) input

## Interfaces

<b>Ethernet</b>	Rj45 socket for 10/100Base-TX Ethernet with Link/Data LEDs; Static IP or DHCP; Power-over-Ethernet (PoE)
<b>Audio In</b>	Stereo balanced line level (0dBV) * *Individually selectable operating mode for contact closure, digital or analog input (24V maximum) *
<b>Relay Inputs</b>	Standard 5-pin DIN *Install-friendly 0.200" (5.08mm) plug in rising clamp connectors (included)

## Specifications

<b>Power Required</b>	PoE (IEEE802.3af, Class 1) 1.5W typical
<b>Addressing</b>	Any Pharos Designer Controller By rotary selector switch
<b>Temperature</b>	0°C to 50°C (32°F to 122°F)
<b>Humidity</b>	10-50% relative, non-condensing
<b>Ingress</b>	IP40
<b>Physical</b>	4 unit wide DIN rail mounting enclosure (DIN43880 / EN60715 (35/7.5 rail)) 0.3 kg (0.7 lbs)
<b>Shipping</b>	20 x 15 x 12 cm (8" x 6" x 5") 0.5 kg (1.1 lbs)
<b>Recovery</b>	Hardware watchdog and recessed reset button

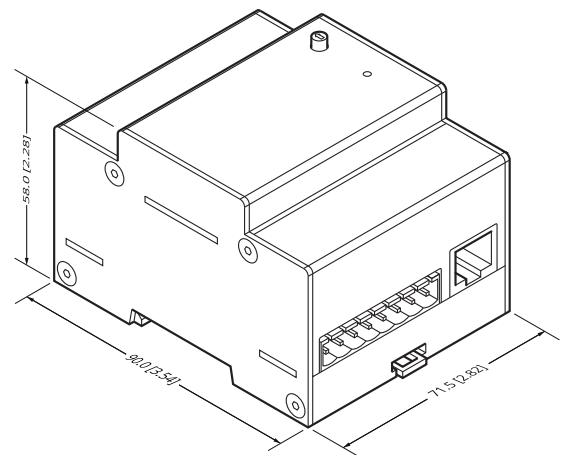

## Order Code & Variants

<b>RIO A</b>	Designer Remote Audio Input Device (Stereo Audio in, LTC, MIDI in and out)
--------------	---

*Pharos Designer Controller required*

## Warranty & Certifications

<b>Warranty</b>	5 years
<b>Certifications</b>	CE compliant, UKCA compliant, ETL/cETL listed.

