

Wiring diagram POWERdrive 561/S, 561/A

(PW0561S1, PW0561A1)

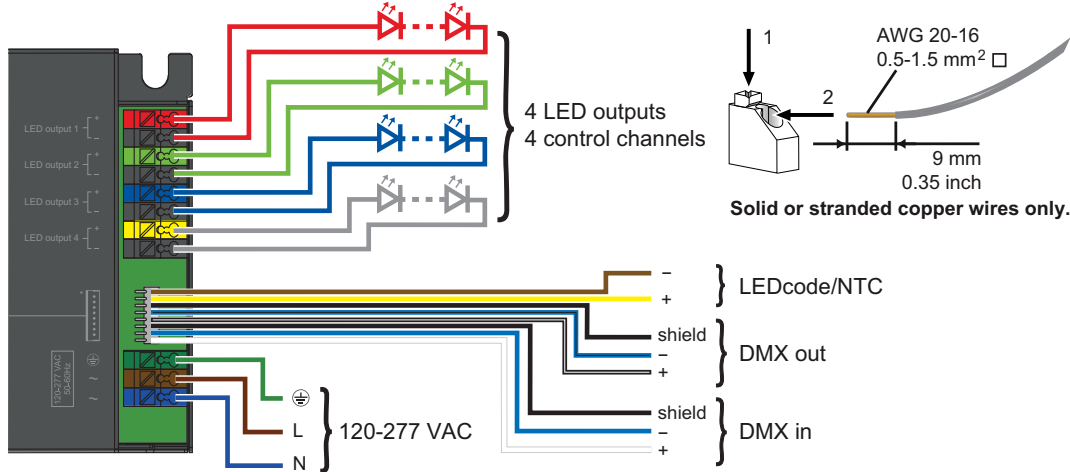

Pay attention when connecting the LED groups:
polarity reversal results in no light output and often damages the LEDs



WARNING: Risk of electrical shock. May result in serious injury or death. Disconnect power before servicing or installing.



CAUTION: The device may only be connected and installed by a qualified electrician. All applicable regulations, legislation and building codes must be observed. Incorrect installation of the device can cause irreparable damage to the device and the connected LEDs.

LED outputs

R(ed) represents channel 1, G(reen) represents channel 2, B(lue) represents channel 3, and W(hite) represents channel 4. The default group colour allocation can be changed using the TOOLbox pro and freely available FluxTool application.

Maximum wiring distance at full load (from LED driver to LED load):

AWG value	20	19	18	17	16
Distance (m)	14	18	22	28	36
Distance (ft)	46	59	72	92	118



Please observe voltage drop over long cable lengths.



Longer cable lengths increase EMI susceptibility.



For POWERdrive 561/A it is recommended to use shielded multi-core wires between LED driver and LED engine. Properly connect shield to ground on both sides.

LEDcode/NTC

The LEDcode/NTC interface allows connection of a 47kΩ NTC thermistor for closed loop thermal control. The NTC throttle temperature is programmable through the freely available FluxTool software (see "Configuring your driver over DMX in").

DMX in/DMX out

Connect the network cable's DMX+, DMX- and DMX shielding wires to the corresponding pin or wire on the LED driver.

For LED drivers that feature the WH0081S1 wiring harness, the wire colors on the harness and corresponding colors in a CAT 5 cable are listed in the following table.

	Wiring harness	CAT5 cable
DMX out shield	black	brown
DMX out -	black/blue	orange
DMX out +	black/white	orange/white
DMX in shield	black	brown
DMX in -	blue	orange
DMX in +	white	orange/white

The WH0081S1 wiring harness can be ordered from eldoLED.

Alternatively, if you wish to use a proprietary solution, the following moxex parts should be used: 1x wire-to-board housing 87439-0800 and 8x crimp terminal 87421-0000.

Configuring your driver over DMX in

Download the FluxTool software from your eldoLED driver's product web page and connect a TOOLbox pro to DMX in to configure your driver. You can configure:

- various DMX parameters
- dimming curve
- minimum dimming level
- NTC throttle temperature
- LED drive current per output, from 200mA-1,050mA in 1mA steps

120-277V AC

The driver has been designed for use with universal mains voltage input (120-277V AC, 50/60Hz), and for use with DC input (120-250V, as used in emergency lighting).

Connecting 3 LED groups

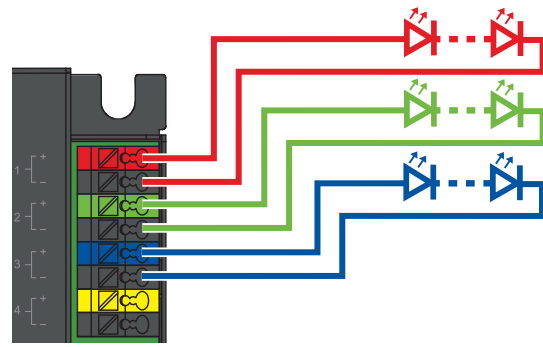

Connecting 2 LED groups

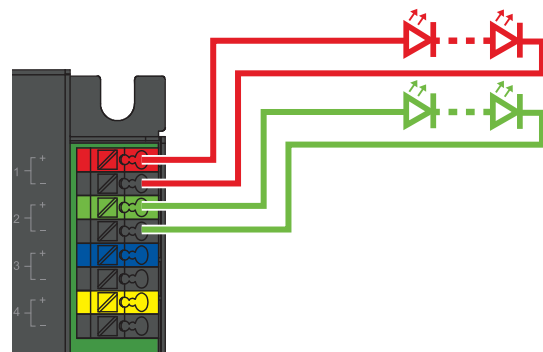

Connecting 1 LED group

