

Table of Contents

1. Technical characteristics	4
1.1 Input characteristics	4
1.2 Output characteristics	5
1.3 Control characteristics	5
1.4 Protection	5
1.5 Thermal characteristics	5
1.6 Thermal protection	6
1.7 Dimensions, weight and packaging	6
1.8 Standards compliance	6
1.9 Certifications	6
2. Wiring	7
2.1 Wiring specifications	7
2.1.1 General wiring specifications	7
2.1.2 Power cord requirements	7
2.1.3 Sample voltage drop calculation	8
2.2 Connections	8
2.2.1 DMX network options	9
2.2.2 LED outputs	11
2.2.3 LEDcode/NTC	12
2.2.4 0-10V	12
2.2.5 DALI	12
2.2.6 120-230V AC	12
3. Installing the POWERdrive 6060/R	13
3.1 Cable connections	13
3.2 Common practice for grounding LED wires	14
3.3 Cable trunk	15
4. Configuring POWERdrive 6060/R	16
4.1 Menu button combinations	16
4.2 Order of LED driver configuration	16
4.3 Setting the operation mode	17
4.4 Setting the LED output current and LED group configuration	17

Safety guidelines	20
Disclaimer	21
Warranty	22

1. Technical characteristics

1.1 Input characteristics

Input voltage AC	120-230V
Input current	6.3A max @ 120V / 60Hz 5A max @ 230V / 50Hz
Input frequency	50-60Hz
Power factor	>0.9 @ 25% load and higher
Total Harmonic Distortion	<20% between 2/3 load and full load
Efficiency @ full load	91.8%
Efficiency @ 2/3 load	91.2%
Inrush current	35A @ 115V AC 70A @ 230V AC
Surge protection	EN 61000-4-5 compliant
Standby power	12.5W @ 100V AC 12.8W @ 120V AC 14.4W @ 230V AC

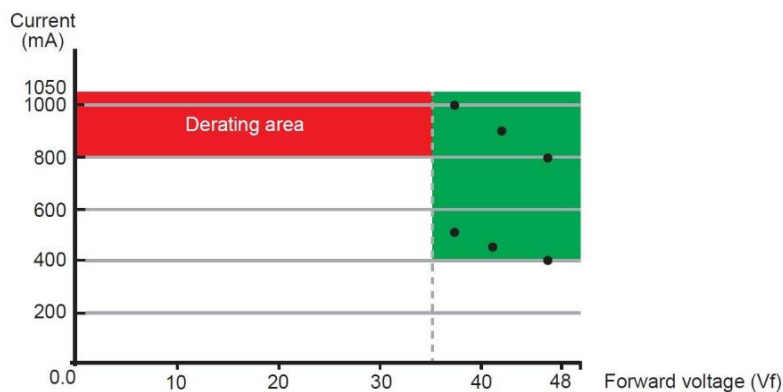

Figure 1.1 Derating diagram

To avoid temperature rise affecting lifetime, it is recommended not to use configurations in the derating area of the diagram above. The green area indicates the highest efficiency area of POWERdrive 6060/R.

Calculation examples in the high efficiency area, using the formula (number of LED outputs) * (Iout) * (VLED)

Using all 32 LED outputs:

- 32 LED outputs * 0.5A * 37.5V = 600W
- 32 LED outputs * 0.45A * 41.6V = 599W
- 32 LED outputs * 0.4A * 46.8V = 600W

Using 16 LED outputs:

- 16 LED outputs * 1A * 37.5V = 600W
- 16 LED outputs * 0.9A * 41.6V = 599W
- 16 LED outputs * 0.8A * 46.8V = 600W

1.2 Output characteristics

LED outputs	32
LED output power	600W max
LED output voltage range	2-48V
LED output current range	200-1,050mA
LED output current resolution	Programmable in 50mA steps
LED output current accuracy	+/- 10%

1.3 Control characteristics

Control channels	1-32 over DMX/RDM, 1-4 over DALI, 1 over 0-10V
Dimming protocol	USITT DMX512A // RDM, DALI or 0-10V
Dimming range	100%-0%
Dimming method	Hybrid HydraDrive
Dimming curve	Linear, logarithmic, square
Driver configuration	via front display and menu buttons
Isolation 0-10V to line voltage input	1500V
Isolation 0-10V to LED output	3750V
0-10V current draw	2mA

1.4 Protection

LED output short	Yes
LED output cross short	Yes
Overload	Yes
Reverse polarity	Yes, for LED output
Restart after protection	

1.5 Thermal characteristics

Ta operating range	-20 °C ... +50 °C / -4 °F ... +122 °F
Tc max	85 °C / 185 °F
Tc lifetime	78 °C / 172 °F

1.6 Thermal protection

External NTC thermistor	Throttling @ 70 °C / 158 °F (settable)
External NTC thermistor value	47kOhm
Recommended NTC thermistor	238164063473 (leaded) NTCASCWE3473J (screw)

1.7 Dimensions, weight and packaging

L x W x H	482.6 x 325 x 44.5mm / 19 x 12.8 x 1.75in
Weight	6.3kg / 13 lb, 14.23 oz
Packaging	1 pc

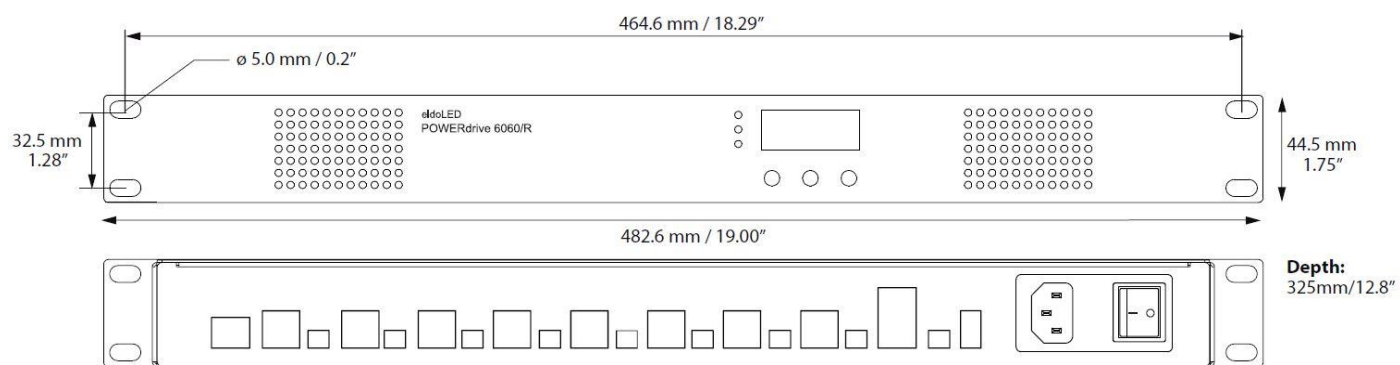

Figure 1.2 POWERdrive 6060/R dimensions

1.8 Standards compliance

EN	EN 55022, EN 62386-101/102/207, EN 60929 Annex E
RoHS	RoHS2

1.9 Certifications

CE	Directives 2004/108/EC, 2006/95/EC, 2011/65/EU
UL	Pending

2. Wiring

2.1 Wiring specifications

2.1.1 General wiring specifications

Wire type	AWG20 – AWG16, 0.5-1.5mm ²
Wire core type	Solid or stranded copper
Wire strip length	9mm, 0.35in

The maximum length of LED wiring is 100m / 328ft from LED output to LED load when using 16 AWG type wires.

Refer to the table below for the maximum LED wiring length for other wire types:

AWG value	20	19	18	17	16
Distance (m)	14	18	22	28	36
Distance (ft)	46	59	72	92	118

Please observe a voltage drop over long wire lengths: the longer the wire length between LED output and LED load, the lower the forward voltage is that is available to you per LED output.

2.1.2 Power cord requirements

Europe excluding UK	certified according to EN50525 norm CEE7 mains plug IEC60320 C13 connector H05VV F3 x 0.75mm ² cable
United Kingdom	certified according to EN50525 norm BS1363A mains plug IEC60320 C13 connector H05VV F3 x 1.0mm ² cable
USA	UL listed NEMA 5-15P mains plug IEC60320 C13 connector S 3x 18AWG/16AWG VCTF3x 0.75mm ² cable Type SP-2, Type SPE-2, Type SPT-2, or heavier cord, minimum 1.5 m (5 ft) in length

2.1.3 Sample voltage drop calculation

Situation 'X':

- Wire resistance (R_{wire}): 0.02Ohm/m (check the specifications of the wire you are using)
- Distance from LED output to LED load (L): 100m
- LED load used (I_f): 1.05A

Calculation of available forward voltage for situation X:

V_f max =

$$48V - (2 * R_{wire} * L * I_f)$$

$$48V - (2 * 0.02 * 100 * 1.05) = 43.8V$$

From the above follows that in situation X you have a voltage drop of $48V - 43.8V = 4.2V$ per LED output



EMI susceptibility will increase with longer wire lengths.

2.2 Connections

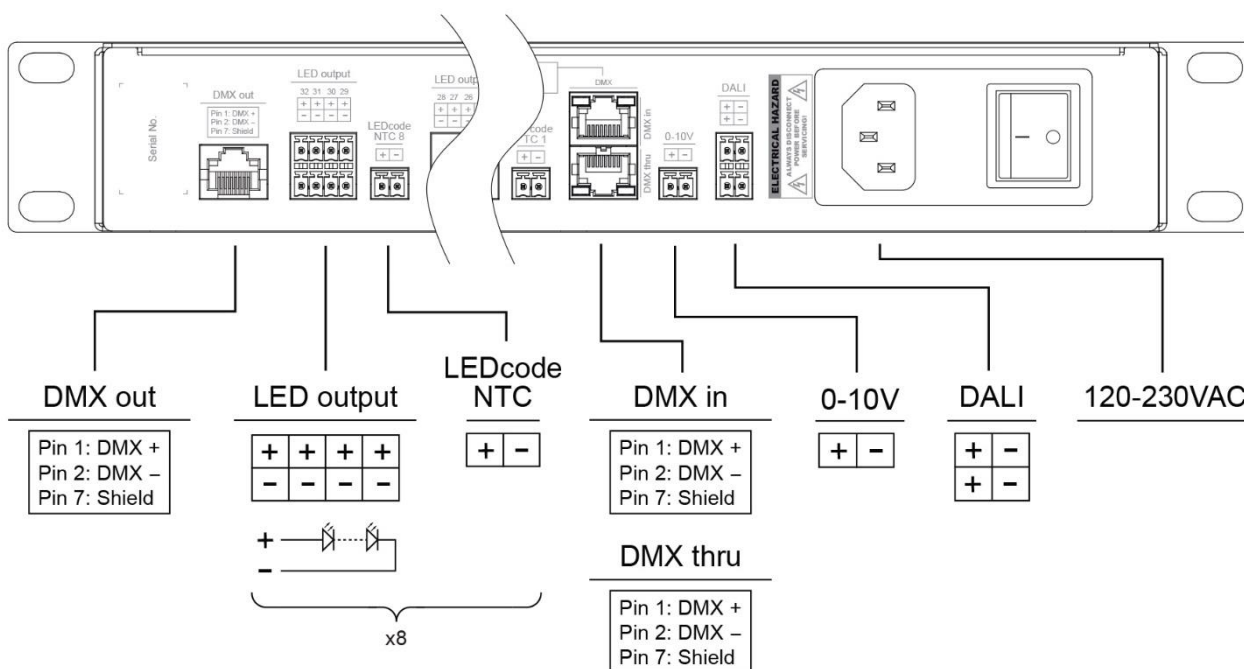

Figure 2.1 POWERdrive 6060/R connections



WARNING: risk of electrical shock. May result in serious injury or death. Disconnect power before servicing or installing.

CAUTION: the device may only be connected and installed by a qualified electrician. All applicable regulations, legislation and building codes must be observed. Incorrect installation of the device can cause irreparable damage to the device and the connected LEDs.

CAUTION: pay attention when connecting the LEDs: polarity reversal results in no light output and often damages the LEDs.

2.2.1 DMX network options

Bussed DMX

To set up a bussed DMX network:

- Use the 'DMX in' and 'DMX thru' connectors as shown in the diagram below
- Set the correct DMX start address for each POWERdrive
- Make sure you terminate the last POWERdrive 6060/R with a resistor that matches the impedance of the cable used as close to its 'DMX in' connector as possible.



DMX+, DMX- and DMX Shield (the orange-white, orange and brown wire in a CAT5 cable) are pin 1, 2 and 7 of the RJ45 connector.

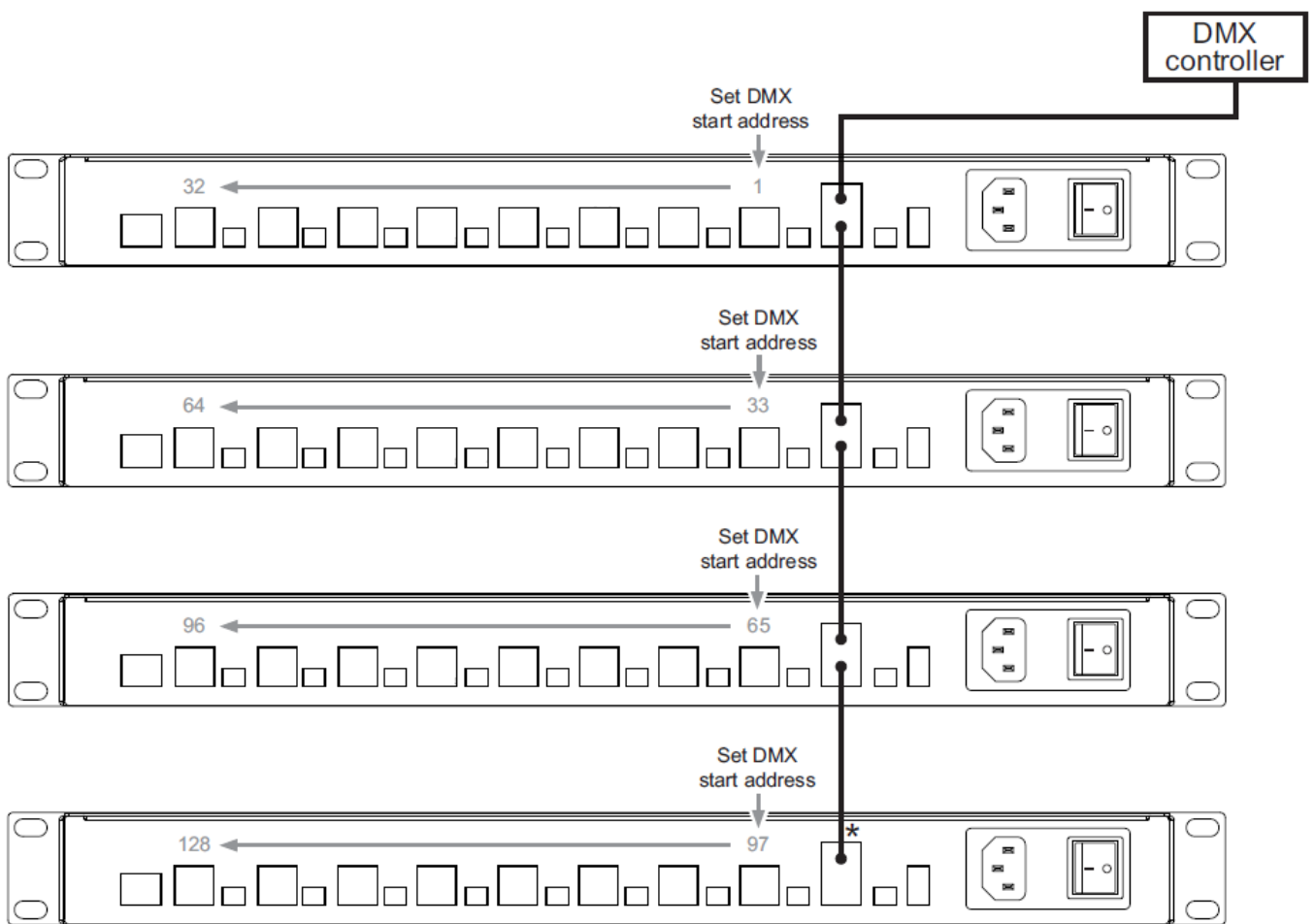

* Terminate last DMX node

Figure 2.2 Bussed DMX

Daisy-chained DMX

To set up a daisy-chained DMX network:

- Use the 'DMX in' and 'DMX out' connectors as shown in the diagram below
- Set the correct DMX start address for the first POWERdrive in a group
- Make sure you terminate the POWERdrives at their 'DMX in' connector when the wire length between drivers is over 20m. Use a resistor that matches the impedance of the cable that has been used.



DMX+, DMX- and DMX Shield (the orange-white, orange and brown wire in a CAT5 cable) are pin 1, 2 and 7 of the RJ45 connector.

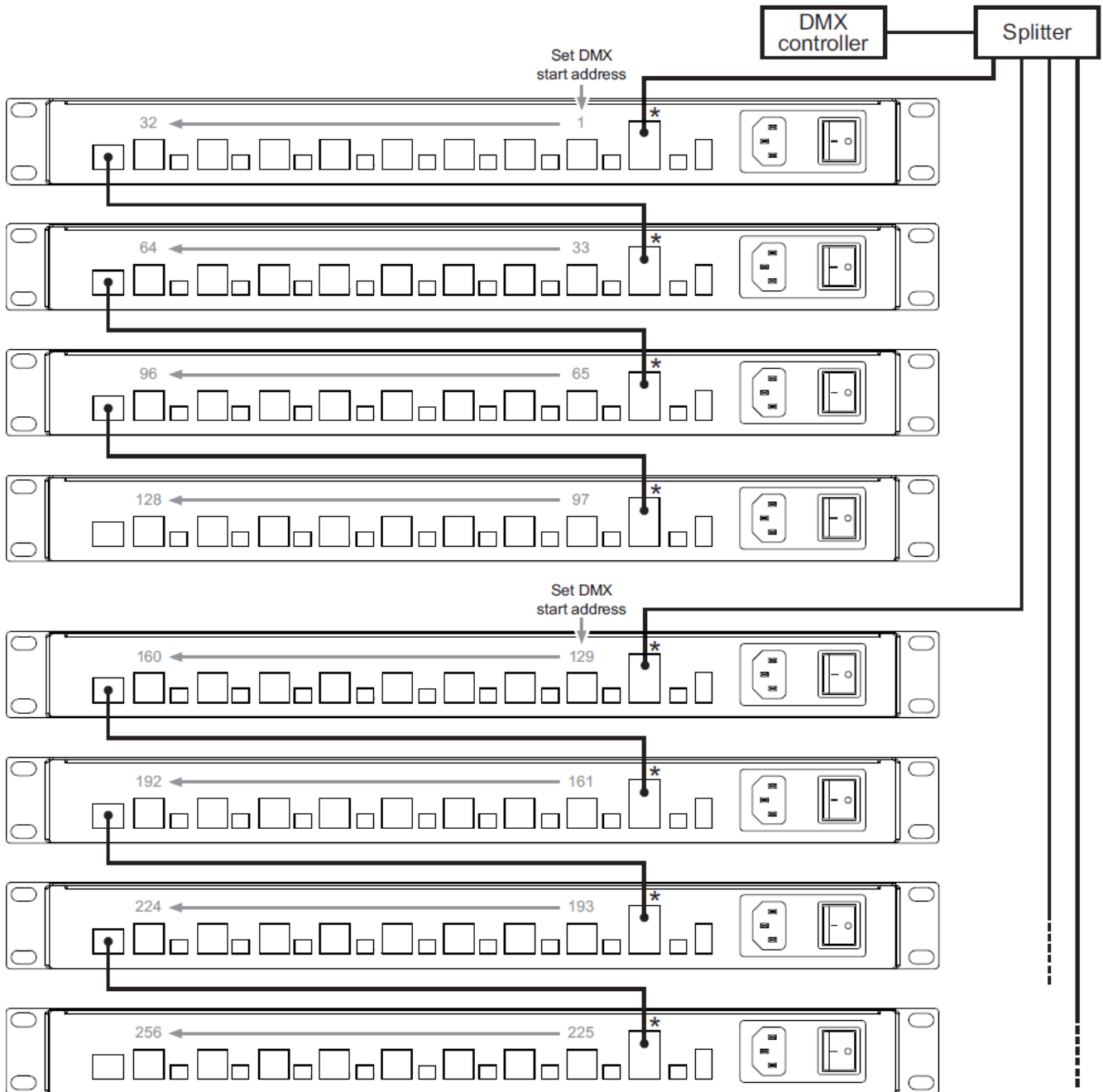

* Terminate using resistor that matches impedance of the cable

Figure 2.3 Daisy-chained (buffered) DMX

2.2.2 LED outputs

POWERdrive 6060/R features 32 LED outputs. Note that if you want to connect an LED load to every LED output, the maximum current per output is 800mA. Refer to Chapter 1, Technical Characteristics, for more information on derating and LED wiring.

LED outputs controlled over DMX/RDM

When you are using the DMX or RDM protocol, you can assign a DMX address to every single LED output. For configuration options such as LED output current, however, the LED outputs are grouped according to the corresponding current sources.

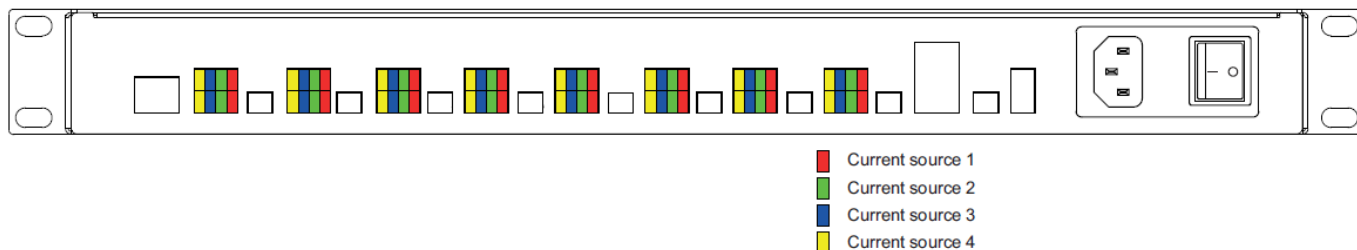

Figure 2.4 POWERdrive 6060/R LED outputs and corresponding current sources

LED outputs controlled over DALI

When you are using the DALI protocol, you can define up to 4 DALI ballasts for every POWERdrive 6060/R with your DALI commissioning tool.

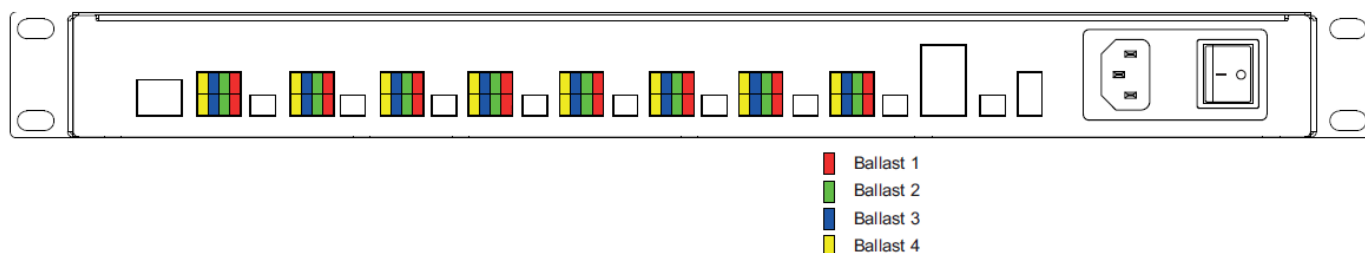

Figure 2.5 Up to 4 DALI ballasts

LED outputs controlled over 0-10V

When you are controlling the POWERdrive 6060/R over 0-10V, all LED outputs are controlled over the same channel, i.e. all LED outputs will show the same behavior.

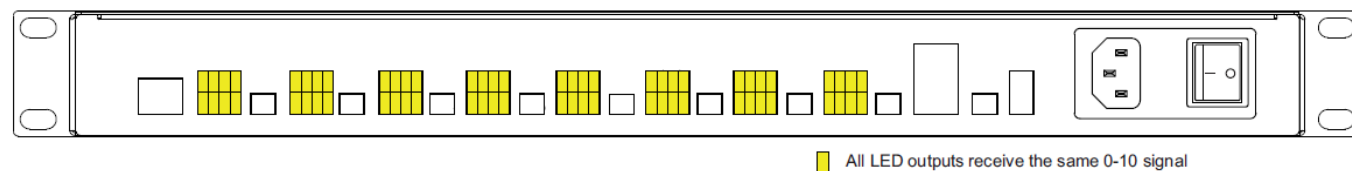

Figure 2.6 One 0-10V control channel

2.2.3 LEDcode/NTC

For extensive thermal management purposes, you can use an NTC thermistor. This sensor can be fastened on or near the LED engine, and its wires connected to the LEDcode/NTC connectors.



Figure 2.7 Examples of NTC thermistors

The NTC thermistor feeds the temperature values that it detects to the driver. Whenever these values exceed the predefined NTC temperature limit, the driver will gradually decrease the light output until normal operating temperatures are reached.

You can connect a 47kOhm NTC thermistor to the LEDcode/NTC interface for this closed loop thermal control. Recommended NTC thermistors include:

- 238164063472 (leaded)
- NTCASCWE3473J (screw)

2.2.4 0-10V

Connect your 0-10V control device to the '0-10V+' and '0-10V-' connector on the POWERdrive 6060/R.

2.2.5 DALI

Use the DALI connectors to connect the POWERdrive 6060/R to a DALI network. Always combine a DA+ and DA- connector for either data input or data output. You can address the LED outputs over a total of 4 DALI ballasts.

2.2.6 120-230V AC

The LED driver has been designed for use with universal mains voltage input of 120-230V AC, 50-60Hz.

3. Installing the POWERdrive 6060/R

This chapter gives guidelines for the installation of POWERdrive 6060/R with regard to cable connections, grounding the LED output wires and use of cable trunks.

3.1 Cable connections

It is recommended that you use shielded cabling for the LED output wires that connect the 19" rack unit to the LED loads in order to reduce EMI (Electromagnetic Interference). This will enable the installing party to meet EMC requirements.

For connection of LED, NTC and LEDcode wires, use the mating connectors listed below:

- 2-pole terminal block, Phoenix contact FMC 1.5/2-ST-3.5-1952267 P1334
- 4-pole terminal block, Phoenix contact FMC 1.5/4-ST-3.5-1952283 P1348

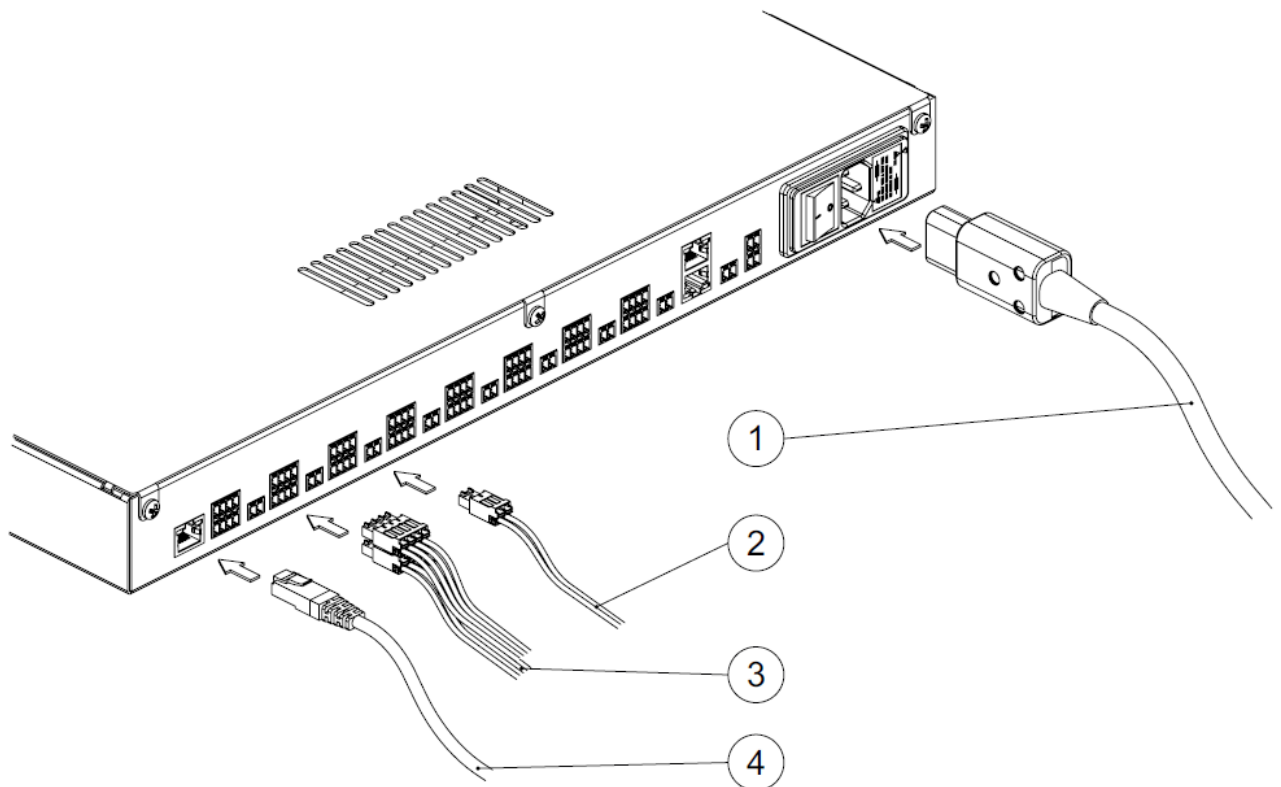

Figure 3.1 Cable connections: mains cable (1), NTC and LEDcode wires (2), LED wires (3) and DMX cable (4)

3.2 Common practice for grounding LED wires

POWERdrive 6060/R has been designed for installation in a 19" rack. It is recommended to ground the shielded LED output cables both at the 19" rack unit and close to the LED load.

Inside the 19" rack unit, ground the LED wires as depicted in Figure 3.3 by leading them through an earthing clamp (2) that is attached to a C-rail (1). Ground the LED wires a second time as close to the LED load as possible.

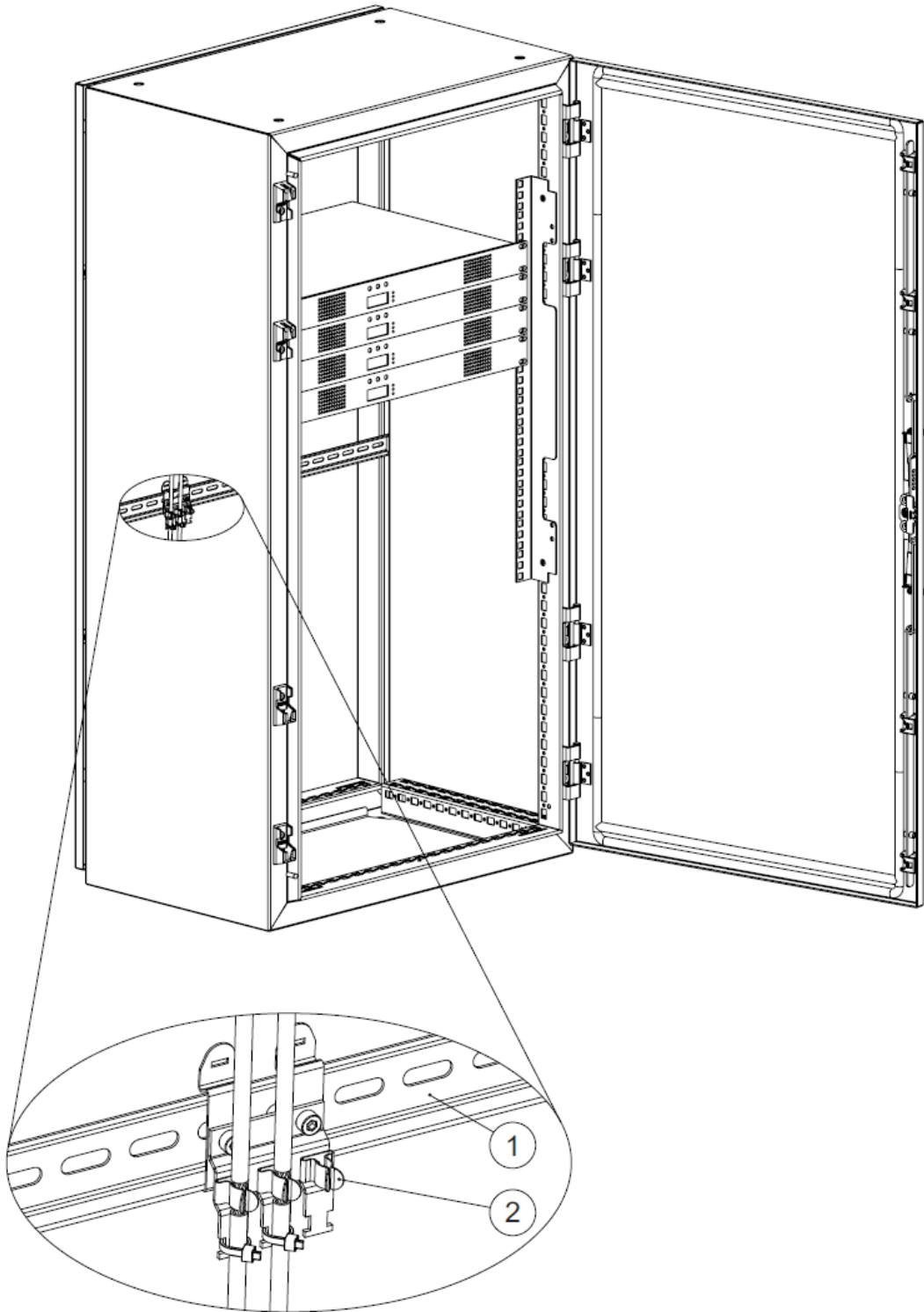

Figure 3.2 Grounding LED wires inside 19" rack unit

3.3 Cable trunk

Cable trunks as depicted in Figure 3.3 will facilitate leading the wires over longer distances inside the building.

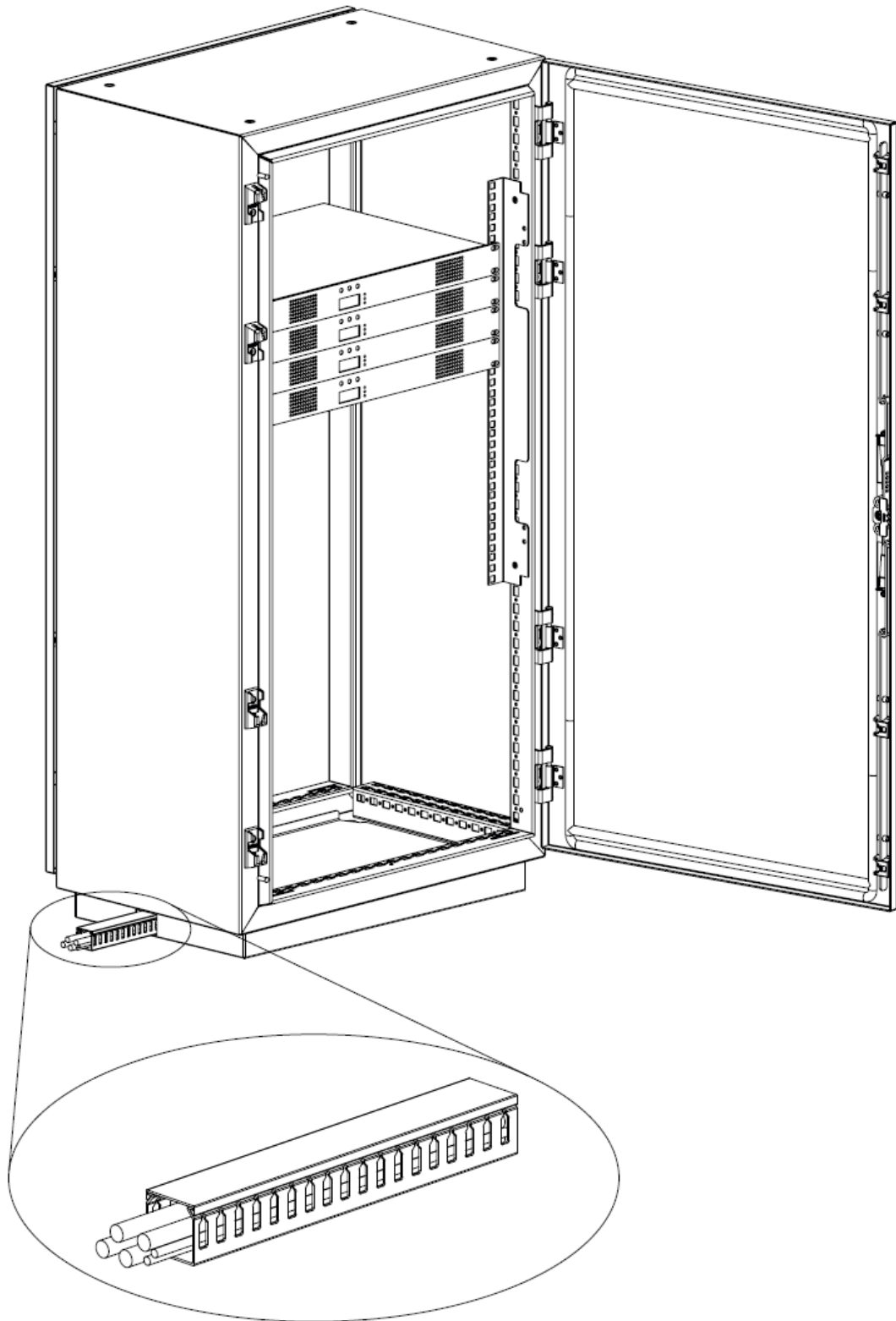

Figure 3.3 Using cable trunks

4. Configuring POWERdrive 6060/R

Configure the POWERdrive 6060/R over its intuitive, 3-button user interface with display. The easy-to-navigate menu allows you to set parameters such as number of LED groups, DMX or DALI settings for networked mode and show/colour/dim values for standalone operation. You can also lock the driver's configuration and perform a test run of the connected LED groups.

This chapter explains how to work with the user interface, and lists the various menu items and selectable values.

4.1 Menu button combinations

POWERdrive 6060/R features three menu buttons on its front side (M, - and +) with which you can navigate the configuration menu. The display above the buttons shows the menu options and values that can be selected for every option.

Pressing the M button

- shows the current mode or the next menu option; use the M button to browse menus and settings without making any changes.
- saves a changed value.
- turns off the display after the last menu option has been displayed.

Pressing the + (plus) or - (minus) button

- changes a value. The changed value is only saved when M is pressed.

Have you accidentally changed a value but haven't confirmed it yet by pressing M? By refraining from pressing the buttons for at least 8 seconds, you will leave the menu (display is turned off) without changing the value.

If you are in a menu and want to change to another menu, refrain from pressing the buttons for at least 8 seconds (display is turned off), and subsequently press the button combination for the menu you want to change to.

4.2 Order of LED driver configuration

The very first time the LED driver is powered on, the display will show the LED driver type (POWER RACK), for a couple of seconds. Next, the display shows "SET MODE". **Set the mode of operation before you move on to the other menu items.**

If the power is interrupted to a POWERdrive 6060/R that has already been configured, the display will only show the driver type when the power comes back on, but will not go to the Set Mode menu, as the driver's configuration has been saved to memory.

Basic configuration of the POWERdrive 6060/R includes the following steps:

1. Set the mode of operation (see 4.3 Setting the operation mode).
2. Set the LED output currents and LED group configuration (see 4.4 Setting the LED output current and LED group configuration).
3. Configure or view the operation mode you have chosen (see 4.5).
4. Optional:

You can do a test run of all connected LEDs by simultaneously pressing the M, - and + buttons

You can hard or soft lock the configuration by simultaneously pressing the M and + button and holding this combination down for 5 seconds

You can reset the driver's configuration to the factory defaults by simultaneously pressing the M, - and + buttons and holding this combination down for 5 seconds

4.3 Setting the operation mode

To enter the SET MODE menu:

1. The very first time the driver is powered on, the display will show the driver type/name for a couple of seconds and then automatically enter the SET MODE menu.

To manually enter the SET MODE menu, press the M button for 5 seconds

The display shows "SET"- "MODE", followed by the name of the currently active operation mode

2. Using the minus or plus button, go to the operation mode of your choice (COLR, SHOW, DMX, DALI or 10V).
3. Press M to save your choice. The display will turn off after you have pressed the M button.

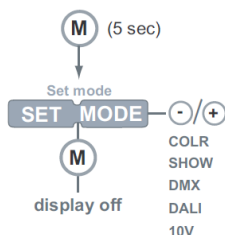

Figure 4.1 Set mode menu



If you have confirmed COLR as the mode of operation, it is recommended to set the LED groups and the LED output current first, before entering the COLR menu to set the color of your choice: if the LED current is not set correctly (e.g. too low), there might not be any light output for you to verify the color.

4.4 Setting the LED output current and LED group configuration

In the setup menu, you can configure the LED output currents per current source, set the LED group configuration, and define the NTC temperature.



Ensure that the LEDs you're connecting to the driver can handle the LED output current! For instance, connecting 500mA LEDs to a driver that has been configured for a 700mA output current will blow up the LEDs!

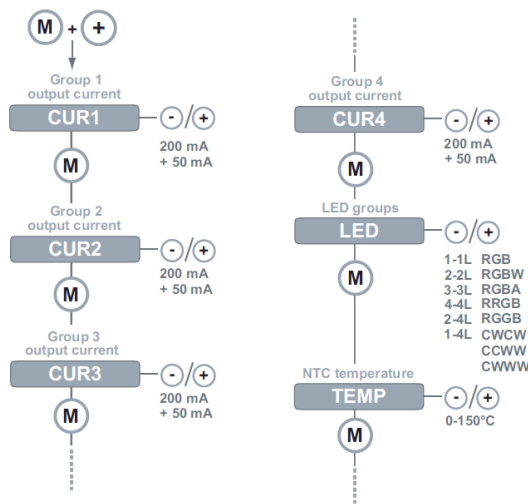

Figure 4.2 Configuring LED output current, LED group configuration, NTC temperature

To set LED output currents and LED group configurations:

1. Press M and the plus button simultaneously.
2. In the first menu (CUR1), select the LED output current for the current source 1. Figure 4.3 shows which current sources the LED outputs are connected to. By pressing the plus or minus button you can go up or down in 50mA steps.

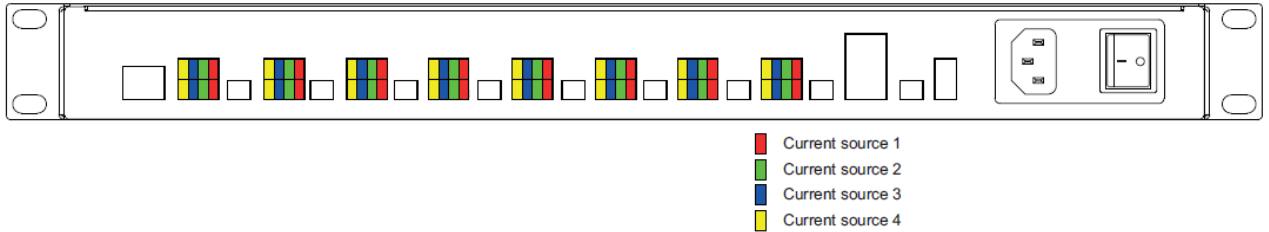















































Figure 4.3 Current sources and corresponding LED outputs













3. Press M to save your choice, and repeat the same exercise for the LED outputs connected to current source 2 (CUR2), 3 (CUR3) and 4 (CUR4). Always save your selection by pressing M.
4. In the LED menu item, select the configuration of the LED groups that best fits your application. The below figures show the possibilities offered in this menu item.

The LED group in pictures below refers to the Figure 4.3, which shows which current sources the LED outputs are connected to.

<p>1-1L</p> <table border="1" style="width: 100%; border-collapse: collapse;"> <thead> <tr> <th style="font-size: small;">Control channel</th> <th style="font-size: small;">LED group</th> </tr> </thead> <tbody> <tr> <td style="text-align: center;">1</td> <td style="text-align: center;">1 - - - </td> </tr> <tr> <td style="text-align: center;">X</td> <td style="text-align: center;">x</td> </tr> <tr> <td style="text-align: center;">X</td> <td style="text-align: center;">x</td> </tr> <tr> <td style="text-align: center;">X</td> <td style="text-align: center;">x</td> </tr> </tbody> </table>	Control channel	LED group	1	1 - - -	X	x	X	x	X	x	<p>1-4L</p> <table border="1" style="width: 100%; border-collapse: collapse;"> <thead> <tr> <th style="font-size: small;">Control channel</th> <th style="font-size: small;">LED group</th> </tr> </thead> <tbody> <tr> <td rowspan="4" style="text-align: center; vertical-align: middle;">1</td> <td style="text-align: center;">1 - - - </td> </tr> <tr> <td style="text-align: center;">2 - - - </td> </tr> <tr> <td style="text-align: center;">3 - - - </td> </tr> <tr> <td style="text-align: center;">4 - - - </td> </tr> </tbody> </table>	Control channel	LED group	1	1 - - -	2 - - -	3 - - -	4 - - -			
Control channel	LED group																				
1	1 - - -																				
X	x																				
X	x																				
X	x																				
Control channel	LED group																				
1	1 - - -																				
	2 - - -																				
	3 - - -																				
	4 - - -																				
<p>2-2L</p> <table border="1" style="width: 100%; border-collapse: collapse;"> <thead> <tr> <th style="font-size: small;">Control channel</th> <th style="font-size: small;">LED group</th> </tr> </thead> <tbody> <tr> <td style="text-align: center;">1</td> <td style="text-align: center;">1 - - - </td> </tr> <tr> <td style="text-align: center;">2</td> <td style="text-align: center;">2 - - - </td> </tr> <tr> <td style="text-align: center;">X</td> <td style="text-align: center;">x</td> </tr> <tr> <td style="text-align: center;">X</td> <td style="text-align: center;">x</td> </tr> </tbody> </table>	Control channel	LED group	1	1 - - -	2	2 - - -	X	x	X	x	<p>2-4L</p> <table border="1" style="width: 100%; border-collapse: collapse;"> <thead> <tr> <th style="font-size: small;">Control channel</th> <th style="font-size: small;">LED group</th> </tr> </thead> <tbody> <tr> <td rowspan="4" style="text-align: center; vertical-align: middle;">1</td> <td style="text-align: center;">1 - - - </td> </tr> <tr> <td style="text-align: center;">2 - - - </td> </tr> <tr> <td style="text-align: center;">3 - - - </td> </tr> <tr> <td style="text-align: center;">4 - - - </td> </tr> </tbody> </table>	Control channel	LED group	1	1 - - -	2 - - -	3 - - -	4 - - -			
Control channel	LED group																				
1	1 - - -																				
2	2 - - -																				
X	x																				
X	x																				
Control channel	LED group																				
1	1 - - -																				
	2 - - -																				
	3 - - -																				
	4 - - -																				
<p>3-3L</p> <table border="1" style="width: 100%; border-collapse: collapse;"> <thead> <tr> <th style="font-size: small;">Control channel</th> <th style="font-size: small;">LED group</th> </tr> </thead> <tbody> <tr> <td style="text-align: center;">1</td> <td style="text-align: center;">1 - - - </td> </tr> <tr> <td style="text-align: center;">2</td> <td style="text-align: center;">2 - - - </td> </tr> <tr> <td style="text-align: center;">3</td> <td style="text-align: center;">3 - - - </td> </tr> <tr> <td style="text-align: center;">X</td> <td style="text-align: center;">x</td> </tr> </tbody> </table>	Control channel	LED group	1	1 - - -	2	2 - - -	3	3 - - -	X	x	<p>4-4L</p> <table border="1" style="width: 100%; border-collapse: collapse;"> <thead> <tr> <th style="font-size: small;">Control channel</th> <th style="font-size: small;">LED group</th> </tr> </thead> <tbody> <tr> <td style="text-align: center;">1</td> <td style="text-align: center;">1 - - - </td> </tr> <tr> <td style="text-align: center;">2</td> <td style="text-align: center;">2 - - - </td> </tr> <tr> <td style="text-align: center;">3</td> <td style="text-align: center;">3 - - - </td> </tr> <tr> <td style="text-align: center;">4</td> <td style="text-align: center;">4 - - - </td> </tr> </tbody> </table>	Control channel	LED group	1	1 - - -	2	2 - - -	3	3 - - -	4	4 - - -
Control channel	LED group																				
1	1 - - -																				
2	2 - - -																				
3	3 - - -																				
X	x																				
Control channel	LED group																				
1	1 - - -																				
2	2 - - -																				
3	3 - - -																				
4	4 - - -																				
<p>CCWW</p> <table border="1" style="width: 100%; border-collapse: collapse;"> <thead> <tr> <th style="font-size: small;">Control channel</th> <th style="font-size: small;">LED group</th> </tr> </thead> <tbody> <tr> <td rowspan="2" style="text-align: center; vertical-align: middle;">1</td> <td style="text-align: center;">1 - - - </td> </tr> <tr> <td style="text-align: center;">2 - - - </td> </tr> <tr> <td rowspan="2" style="text-align: center; vertical-align: middle;">2</td> <td style="text-align: center;">3 - - - </td> </tr> <tr> <td style="text-align: center;">4 - - - </td> </tr> </tbody> </table>	Control channel	LED group	1	1 - - -	2 - - -	2	3 - - -	4 - - -	<p>CWWW</p> <table border="1" style="width: 100%; border-collapse: collapse;"> <thead> <tr> <th style="font-size: small;">Control channel</th> <th style="font-size: small;">LED group</th> </tr> </thead> <tbody> <tr> <td rowspan="4" style="text-align: center; vertical-align: middle;">1</td> <td style="text-align: center;">1 - - - </td> </tr> <tr> <td style="text-align: center;">2 - - - </td> </tr> <tr> <td style="text-align: center;">3 - - - </td> </tr> <tr> <td style="text-align: center;">4 - - - </td> </tr> </tbody> </table>	Control channel	LED group	1	1 - - -	2 - - -	3 - - -	4 - - -					
Control channel	LED group																				
1	1 - - -																				
	2 - - -																				
2	3 - - -																				
	4 - - -																				
Control channel	LED group																				
1	1 - - -																				
	2 - - -																				
	3 - - -																				
	4 - - -																				

RGB		RRGB	
Control channel	LED group	Control channel	LED group
1	1 -  -  - 	1	1 -  -  - 
2	2 -  -  - 		2 -  -  - 
3	3 -  -  - 	2	3 -  -  - 
x	x	3	4 -  -  - 

RGGB		RGBW	
Control channel	LED group	Control channel	LED group
1	1 -  -  - 	1	1 -  -  - 
	2 -  -  - 	2	2 -  -  - 
2	3 -  -  - 	3	3 -  -  - 
	4 -  -  - 	4	4 -  -  - 

RGBA	
Control channel	LED group
1	1 -  -  - 
2	2 -  -  - 
3	3 -  -  - 
4	4 -  -  - 

Safety guidelines

Before installing or performing routine maintenance upon this equipment, follow the general precautions listed in this Appendix. Installation should be performed by a qualified licensed electrician. Maintenance should be performed by qualified person(s) familiar with the products' construction and operation and any hazards involved.

Do not install damaged product! This product has been properly packed so that no parts should have been damaged during transit. Inspect to confirm.



WARNING: RISK OF ELECTRIC SHOCK:

- Disconnect or turn off power before installation
 - Verify that supply voltage is correct by comparing it with the product information
 - Make all electrical and grounded connections in accordance with all applicable local code requirements
 - All wiring connections should be capped with UL approved recognized wire connectors
 - All unused connector openings must be capped.
-



WARNING: RISK OF BURN OR FIRE:

- Do not exceed maximum wattage, ratings, or published operating conditions of product
 - Do not overload
 - Follow all manufacturer's warnings, recommendations and restrictions to ensure proper operation of product
-



CAUTION: RISK OF DAMAGE DUE TO ESD (ELECTROSTATIC DISCHARGE):

- ESD can damage product(s). Personal grounding equipment must be worn during all installation of the unit.
 - Do not touch individual electrical components as this can cause ESD and affect product performance.
-



CAUTION: RISK OF PRODUCT DAMAGE:

- Do not stretch or use cable sets that are too short or are of insufficient length.
 - Do not tamper with contacts.
 - Do not modify the product.
 - Do not change or alter internal wiring or installation circuitry.
 - Do not use product for anything other than its intended use.
-

Disclaimer

All information and content available on or accessible through the eldoLED website, all information contained in any eldoLED documentation, whether provided electronically or in hardcopy, such as product manuals, and all information and content in e-mails or other ways of communication used by eldoLED, (collectively hereafter referred to as: 'the Information') has been prepared solely for the purpose of providing information about eldoLED products and the eldoLED companies ("eldoLED" as used herein, refers to eldoLED B.V. and any of its affiliated companies.) While the content hereof has been prepared by eldoLED with the utmost care, some information may nevertheless be incomplete, incorrect or may become outdated in time.

TO THE FULLEST EXTENT PERMISSIBLE BY LAW, ELDOLED MAKES NO REPRESENTATIONS OR WARRANTIES OF ANY KIND, WHETHER EXPRESS OR IMPLIED, FOR THE CURRENCY, ACCURACY, OR COMPLETENESS OF ANY INFORMATION, AS DEFINED ABOVE.

FURTHERMORE, ELDOLED MAKES NO REPRESENTATIONS OR WARRANTIES IN CONNECTION TO ITS PRODUCTS, INCLUDING WARRANTIES ABOUT ITS PRODUCTS' MERCHANTABILITY OR FITNESS FOR A PARTICULAR PURPOSE, UNLESS EXPLICITLY MADE AND PROVIDED BY ELDOLED IN WRITING TO THE PURCHASER OF ITS PRODUCTS. The provided Information must not be relied upon in connection with any investment decision. eldoLED B.V. cannot be held liable for any direct or indirect loss or damage resulting from the use of the Information and/or resulting from the use of its products or material(s), except in the event of actions verging on eldoLED's gross intent or intentional recklessness. ELDOLED'S MAXIMUM AGGREGATE LIABILITY FOR ANY CAUSES WHATSOEVER, AND REGARDLESS OF THE FORM OF ACTION, WILL AT TIMES BE LIMITED TO 100,- EURO OR THE PURCHASE AMOUNTS PAID TO ELDOLED, IF ANY, IN CONNECTION TO THE PRODUCTS ON WHICH THE LIABILITY CLAIM IS BASED.

All intellectual property rights relating to the Information and all eldoLED products, belong to and remain with eldoLED B.V. and/or its licensor(s) at all times. The Information and the eldoLED products may not be used in any way without eldoLED B.V.'s and/or its licensor's prior explicit written consent. eldoLED develops and produces building blocks for control of LED lighting. Continuous technological innovation being one of the pillars of eldoLED's company philosophy, eldoLED has developed and continues to develop breakthrough solutions in the field of solid-state lighting. eldoLED's steadily growing IP portfolio proves eldoLED's commitment to help its customers to bring SSL applications to a higher level. Because of eldoLED's leading position in the field and its sophisticated knowledge of the market, it is very unlikely that its products infringe upon intellectual property rights of third parties. However, due to the nature of intellectual property protection (e.g. the secretive nature of patent applications), eldoLED, like any other company, cannot give any warranties in this respect. Furthermore, eldoLED cannot vouch for any system built by a third party in which eldoLED's building blocks are comprised. The laws of the Netherlands govern this website and (the use of) the Information, the sale and use of any of the eldoLED products, and all business relationships between eldoLED and third parties. Disputes will be submitted exclusively to the applicable judge of the court in 's-Hertogenbosch, the Netherlands.

ANY CAUSE OF ACTION ARISING OUT OF OR RELATED TO THIS WEBSITE, (THE USE OF) THE INFORMATION, OR ANY OF THE ELDOLED PRODUCTS, MUST COMMENCE WITHIN ONE (1) YEAR AFTER THE CAUSE OF ACTION ACCRUES. OTHERWISE, SUCH CAUSE OF ACTION IS PERMANENTLY BARRED.

Warranty

All information and content available on or accessible through the eldoLED website, all information contained in any eldoLED documentation, whether provided electronically or in hardcopy, such as product manuals, and all information and content in e-mails or other ways of communication used by eldoLED, (collectively hereafter referred to as: 'the Information') has been prepared solely for the purpose of providing information about eldoLED products and the eldoLED companies ("eldoLED" as used herein, refers to eldoLED B.V. and any of its affiliated companies.) While the content hereof has been prepared by eldoLED with the utmost care, some information may nevertheless be incomplete, incorrect or may become outdated in time. TO THE FULLEST EXTENT PERMISSIBLE BY LAW, ELDOLED MAKES NO REPRESENTATIONS OR WARRANTIES OF ANY KIND, WHETHER EXPRESS OR IMPLIED, FOR THE CURRENCY, ACCURACY, OR COMPLETENESS OF ANY INFORMATION, AS DEFINED ABOVE.

FURTHERMORE, ELDOLED MAKES NO REPRESENTATIONS OR WARRANTIES IN CONNECTION TO ITS PRODUCTS, INCLUDING WARRANTIES ABOUT ITS PRODUCTS' MERCHANTABILITY OR FITNESS FOR A PARTICULAR PURPOSE, UNLESS EXPLICITLY MADE AND PROVIDED BY ELDOLED IN WRITING TO THE PURCHASER OF ITS PRODUCTS. The provided Information must not be relied upon in connection with any investment decision. eldoLED B.V. cannot be held liable for any direct or indirect loss or damage resulting from the use of the Information and/or resulting from the use of its products or material(s), except in the event of actions verging on eldoLED's gross intent or intentional recklessness. ELDOLED'S MAXIMUM AGGREGATE LIABILITY FOR ANY CAUSES WHATSOEVER, AND REGARDLESS OF THE FORM OF ACTION, WILL AT TIMES BE LIMITED TO 100,- EURO OR THE PURCHASE AMOUNTS PAID TO ELDOLED, IF ANY, IN CONNECTION TO THE PRODUCTS ON WHICH THE LIABILITY CLAIM IS BASED.

All intellectual property rights relating to the Information and all eldoLED products, belong to and remain with eldoLED B.V. and/or its licensor(s) at all times. The Information and the eldoLED products may not be used in any way without eldoLED B.V.'s and/or its licensor's prior explicit written consent. eldoLED develops and produces building blocks for control of LED lighting. Continuous technological innovation being one of the pillars of eldoLED's company philosophy, eldoLED has developed and continues to develop breakthrough solutions in the field of solid-state lighting. eldoLED's steadily growing IP portfolio proves eldoLED's commitment to help its customers to bring SSL applications to a higher level. Because of eldoLED's leading position in the field and its sophisticated knowledge of the market, it is very unlikely that its products infringe upon intellectual property rights of third parties. However, due to the nature of intellectual property protection (e.g. the secretive nature of patent applications), eldoLED, like any other company, cannot give any warranties in this respect. Furthermore, eldoLED cannot vouch for any system built by a third party in which eldoLED's building blocks are comprised. The laws of the Netherlands govern this website and (the use of) the Information, the sale and use of any of the eldoLED products, and all business relationships between eldoLED and third parties. Disputes will be submitted exclusively to the applicable judge of the court in 's-Hertogenbosch, the Netherlands.

ANY CAUSE OF ACTION ARISING OUT OF OR RELATED TO THIS WEBSITE, (THE USE OF) THE INFORMATION, OR ANY OF THE ELDOLED PRODUCTS, MUST COMMENCE

Europe, Rest of World
eldoLED B.V.
Science Park Eindhoven 5125
5692 ED Son
The Netherlands

E: info@eldoled.com
W: www.eldoled.com

North America
eldoLED America
One Lithonia Way
Conyers, GA 30012
USA

E: info@eldoled.com
W www.eldoled.com