

## Application note Interconnecting VDC- of networked LINEARdrive 720D

This application note applies to the LINEARdrive 720D.

With several power supply units in a DMX network, the possibility exists that their absolute values for VDC- differ from one another. Within the LINEARdrive 720D, the DMX shield is connected to VDC- through a 100Ohm resistor. So if fluctuations occur in the ground of the various power supply units, this creates fluctuations in DMX shield, possibly resulting in random flicker in the light output.

This application note describes how to interconnect the VDC- wiring of the LINEARdrive 720Ds' power supply units, of the LED strips' power supply units and of the DMX controller's power supply unit in order to prevent this random flicker in the light output from occurring.

### Application

The diagram below illustrates a sample application in which several LINEARdrive 720Ds are part of a bussed DMX network. Each LINEARdrive and its LEDs are powered by a separate power supply unit, and the DMX controller has a power supply unit as well.

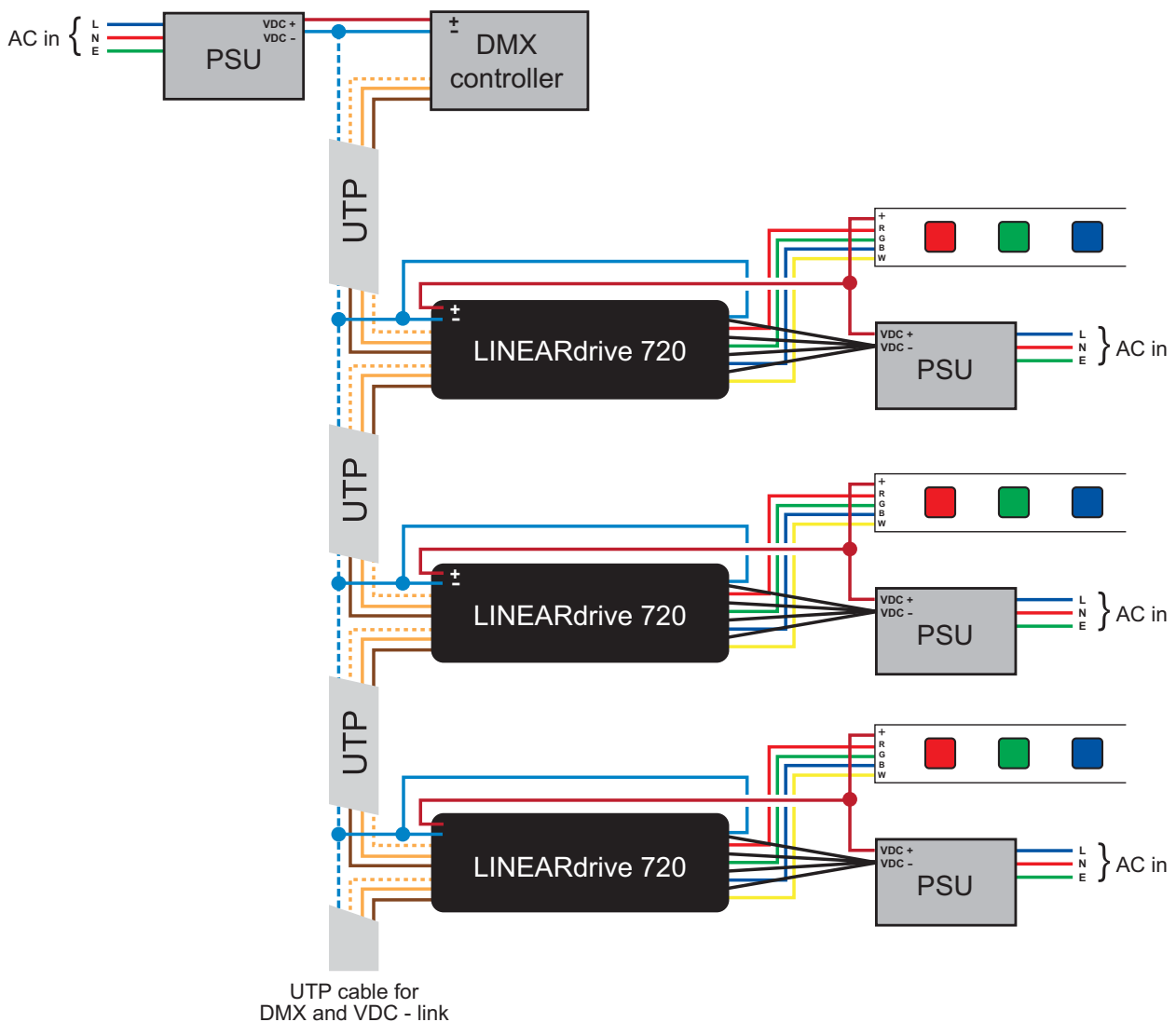

Bussed network of several LINEARdrive 720D drivers

**Wiring**

A CAT5 Unshielded Twisted Pair (UTP) cable is used for the DMX and VDC- connections:

- orange-white wire: DMX in +
- orange wire: DMX in -
- brown wire: DMX in shield
- blue-white wire: VDC-

The close-up below shows:

- the LED driver's VDC+ and the LED strip's + (common anode??) are both connected to the power supply unit's VDC+
- the LED driver's VDC- is connected to the UTP cable's blue-white wire and the first LED output's ground connector
- All LED outputs' ground connectors are connected to the power supply unit's VDC- connector

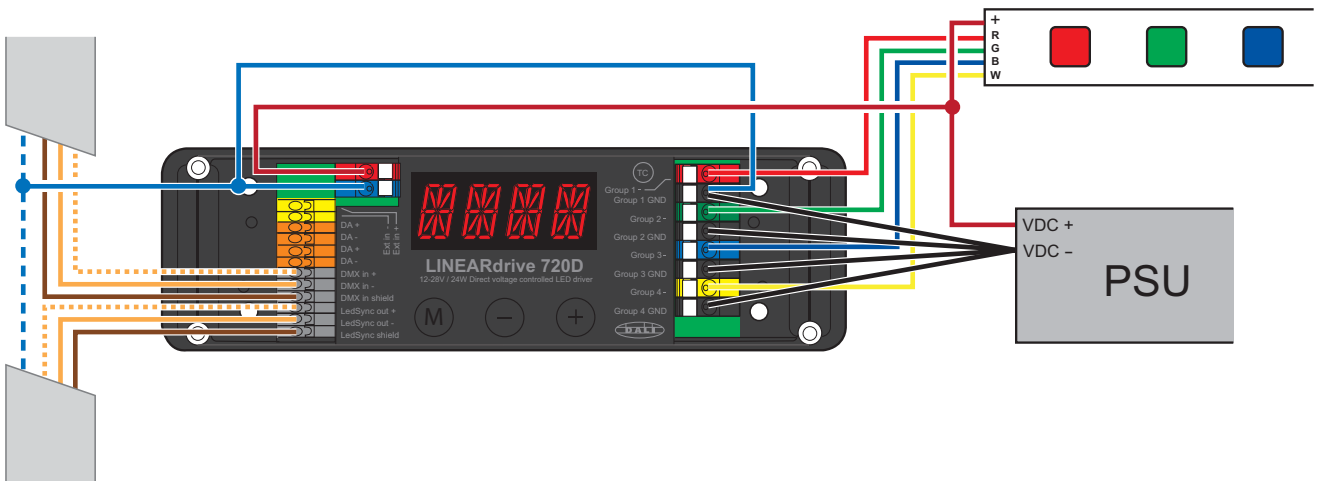

Close-up of DMX and VDC wiring of LINEARdrive 720D driver

**Note regarding wire lengths**

Given the high amperage (24A) that can be facilitated by the LINEARdrive 720D, special attention is required regarding the length of the four wires connecting the LED output GND connectors to the power supply unit's VDC- connector(s) and the wire connecting the LED driver's VDC- connector with the first LED output GND connector.

Please observe a maximum wire length of about 0.5m or 1.64 ft for each of these five wires:

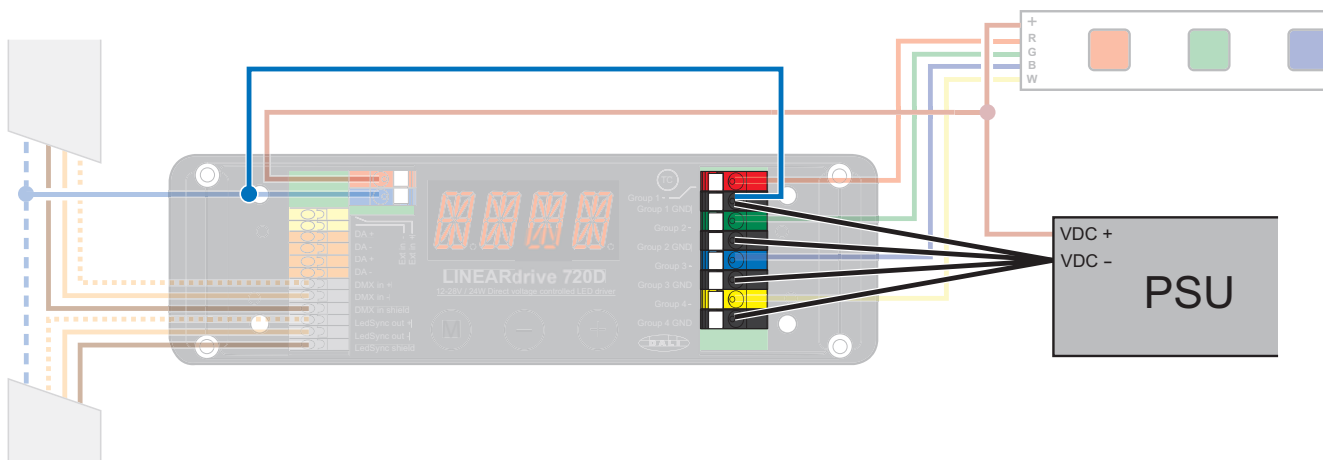

Maximum wire length for VDC-

## Application note Interconnecting VDC- of networked LINEARdrive 720D

If the power supply cannot be positioned within a 0.5m / 1.64 ft vicinity of the LED driver, you can interconnect all four wires coming from the LED output GND connectors (so-called star connection), and then use one longer wire to connect the star connection with the power supply.

The four wires coming from the LED output GND connectors (1) should not be longer than 0.5m or 1.64 ft.

The longer wire connecting the star connection with the power supply (2) can be as long as 10-20m / 33-65 ft. Make sure to measure the voltage at the end of the cable: this should be 12V, 24V or 48V, depending on the type of LED strip you will be connecting. Note that the selection of the wire type is essential in preventing voltage drop.

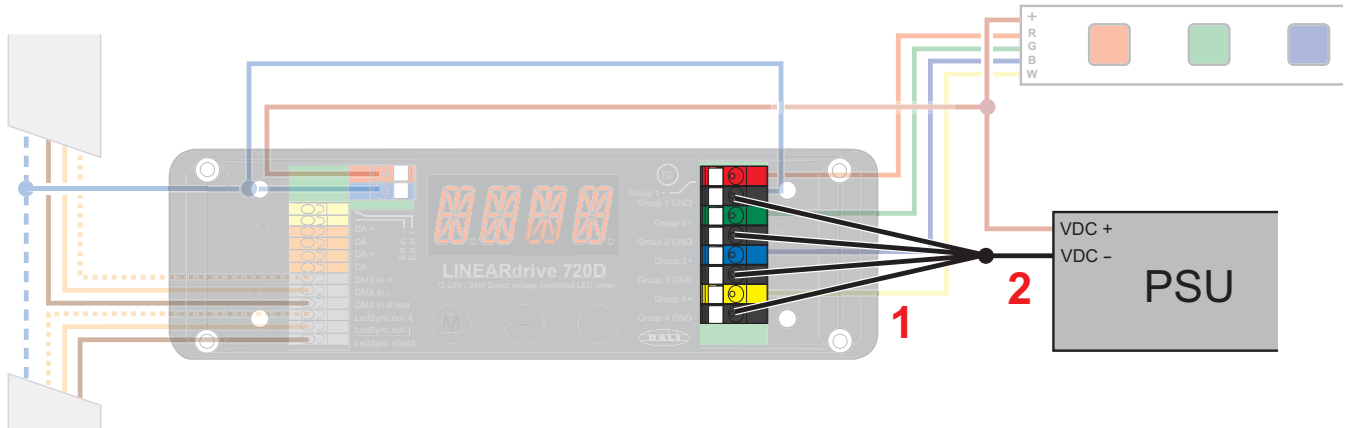

### Europe, Rest of World

eldoLED Europe bv  
Luchthavenweg 18a  
NL-5657 EB Eindhoven  
The Netherlands  
T: +31 40 2054050  
F: +31 40 2054058  
E: info@eldoled.com

### North America

eldoLED America, Inc.  
1762 Technology Drive #226  
San Jose, CA 95110  
USA  
T: +1 408 451-9333  
F: +1 408 451-9335

### Other documentation and support

Visit [www.eldoled.com/support](http://www.eldoled.com/support) for further documentation such as quick start guides, wiring diagrams, tech sheets and 3D IGES files.

### Warranty

eldoLED represents and warrants that for a period of 3 (three) years, as of the date of invoice, Products materially meet the specifications and specifically agreed upon quality, both as stated in the applicable datasheet and/or written design-in specifications, or as stated in writing otherwise by eldoLED, provided that these specifications are explicitly designated by eldoLED as "warranted specifications".

For the complete warranty text, visit [www.eldoled.com/terms](http://www.eldoled.com/terms).